



CETOP-3 Subplate with Relief

Page Number
05.31.10

FEATURES:

- Aluminium alloy body, 2011 T6
- Hard anodised clear finish
- Direct acting relief valve
- Maximum working pressure 210 bar
- Shipping weight 0.95 kg

MODEL	OP111 - A - R - * OP111 - A - R - *
BODY NO.	111010

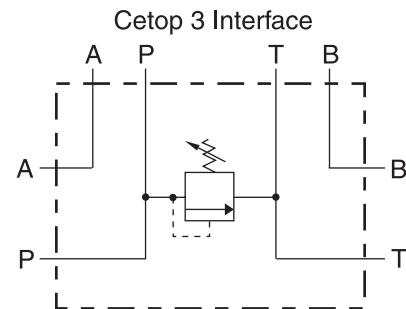
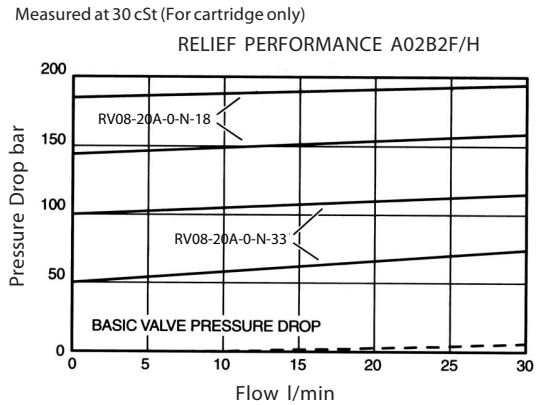
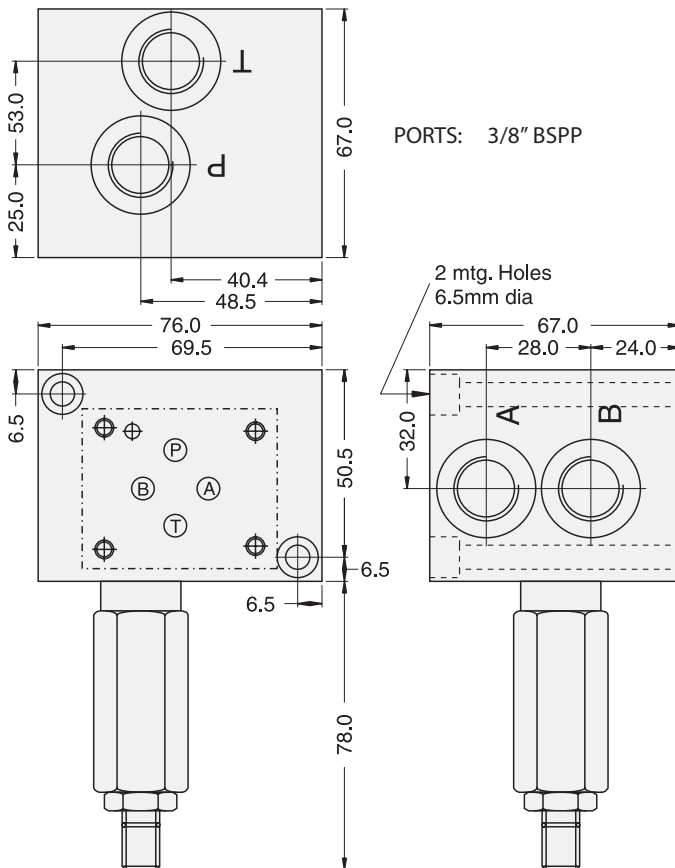

SPECIFICATIONS

Model	Max. Inlet Pressure	Adjustment Range	Relief Valve	Note:
OP111 - A - R - 18	210 Bar	17- 158 Bar	RV08-20A-0-N-18	
OP111 - A - R - 33	210 Bar	17- 210 Bar	RV08-20A-0-N-33	

ORDERING CODE

OP111 - A - R - F - S

Relief valve pressure range refer to Sterling catalogue

Optional, Omit for alloy
S = steel, refer to factory